



SMC™ FLEX

BULLETIN 150

This guide provides you with the basic information required to start up your SMC Flex controller. When reading this document, look for this symbol **“Step x”** to guide you through the four basic steps required to install, start-up, and program the SMC Flex.

The information provided in this Quick Start guide does not replace the User Manual which can be ordered or downloaded by visiting www.ab.com. The Quick Start guide assumes the installer is a qualified person with previous experience and basic understanding of electrical terminology, configuration procedures, required equipment, and safety precautions.

For safety of maintenance personnel as well as others who might be exposed to electrical hazards associated with maintenance activities, follow all local safety related work practices (for example, the NFPA 70E, Part II in the United States). Maintenance personnel must be trained in the safety practices, procedures, and requirements that pertain to their respective job assignments.

For detailed SMC Flex information including set-up, programming, precautions, and application considerations, refer to the following documentation.

Title	Publication Number	Availability
SMC Flex User Manual	150-UM008*	www.ab.com/literature
SMC Flex Application Guide	150-AT002*	www.ab.com/literature

For product technical support:

Online Support	www.ab.com/support
Telephone Support	440-646-5800 (option 2, option 4 or use direct dial code 804)

Step 1 - Read the General Precautions



WARNING

- Only personnel familiar with the controller and associated machinery should plan or implement the installation, start-up, and subsequent maintenance of the system. Failure to do this may result in personal injury and/or equipment damage.
- Hazardous voltage is present in the motor circuit even when the SMC-Flex controller is off. To avoid shock hazard, disconnect main power before working on the controller, motor, and control devices such as Start-Stop push buttons. Procedures that require parts of the equipment to be energized during troubleshooting, testing, etc., must be performed by properly qualified personnel, using appropriate local safety work practices and precautionary measures.
- Failure of solid state power switching components can cause overheating due to a single-phase condition in the motor. To prevent injury or equipment damage, the use of an isolation contactor or shunt trip type circuit breaker on the line side of the SMC is recommended. This device should be capable of interrupting the motor's lock rotor current.
- Hazardous voltages that can cause shock, burn, or death are present on L1, L2, L3, T1, T2, T3, T4, T5, and T6. Power terminal covers for units rated 108...480 A can be installed to prevent inadvertent contact with terminals. Disconnect the main power before servicing the motor controller, motor, or associated wiring.

NOTICE

- The controller contains ESD- (electrostatic discharge) sensitive parts and assemblies. Static control precautions are required when installing, testing, servicing, or repairing the assembly. Component damage may result if ESD control procedures are not followed. If you are not familiar with static control procedures, refer to applicable ESD protection handbooks.
- Stopping modes are not intended to be used as an emergency stop. The user is responsible for determining which stopping mode is best suited to the application. Refer to the applicable standards for emergency stop requirements.
- Pump Stopping may cause motor heating depending on the mechanical dynamics of the pumping system. Therefore, select the lowest stopping time setting that will satisfactorily stop the pump.
- Slow Speed running is not intended for continuous operation due to reduced motor cooling.
- The fan jumpers have been factory installed for 110/120V AC input. Refer to page 9 for 220/240V AC fan wiring (5...480 A devices only).
- Two peripheral devices can be connected to the DPI port. The maximum output current through the DPI port is 280 mA.
- When installing or inspecting protective modules, make sure that the controller has been disconnected from the power source. The protective module should be inspected periodically for damage or discoloration. Replace if necessary.
- An incorrectly applied or installed controller can damage components or reduce product life. Wiring or application errors such as under sizing the motor, over sizing the controller, incorrect or inadequate AC supply, excessive ambient temperatures, or power quality may result in malfunction of the system.
- The Motor Overload parameter must be programmed by the installer to provide proper protection. Overload configuration must be properly coordinated with the motor.
- This product has been designed and tested as Class A equipment for EMC compatibility. Use of the product in domestic environments may cause radio interference, in which case, the installer may need to employ additional mitigation methods.
- Disconnect the controller from the motor before measuring insulation resistance (IR) of the motor windings. Voltages used for insulation resistance testing can cause SCR failure. Do not make any measurements on the controller with an Insulation Resistance (IR or Megger) tester.

Step 2 - Installation

Mounting

Enclosure Ratings	
Standard Device Rating	IP00 (NEMA Open Type)
Minimum Required Enclosure	IP23 (NEMA Type 1)
Recommended Enclosure	IP54 (NEMA Type 12), sizing guide in User Manual
Enclosure Internal Temperature	-5...50 °C (23...122 °F)
Orientation and Clearance	
Mounting Orientation	Vertical
Minimum horizontal clearance	0 cm (0 in.)
Minimum vertical clearance	15 cm (6 in.)

Controllers rated 625...1250 A

Device must be lifted only at the designated lift points identified with labels.

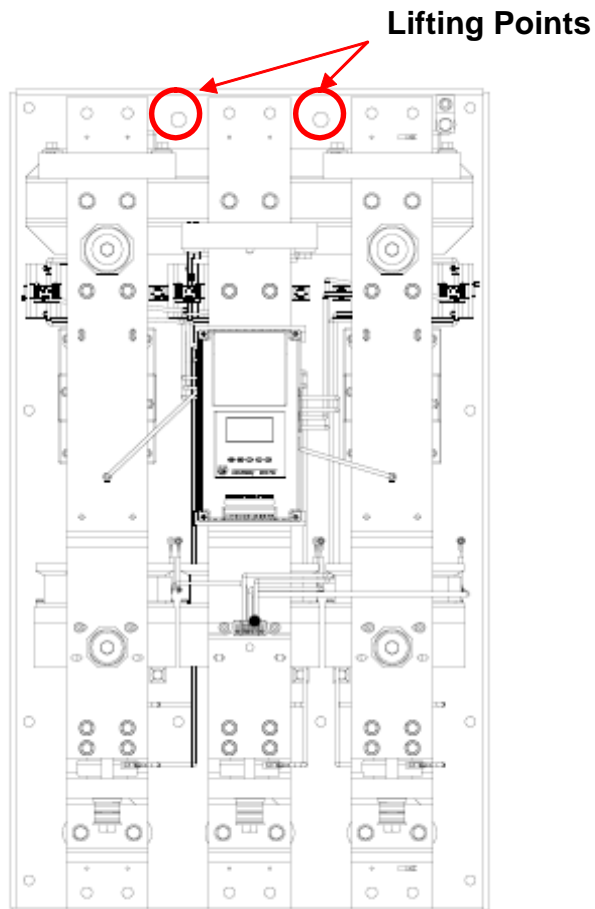

Dimensions

For detailed dimensions, please refer to the SMC Flex User Manual.

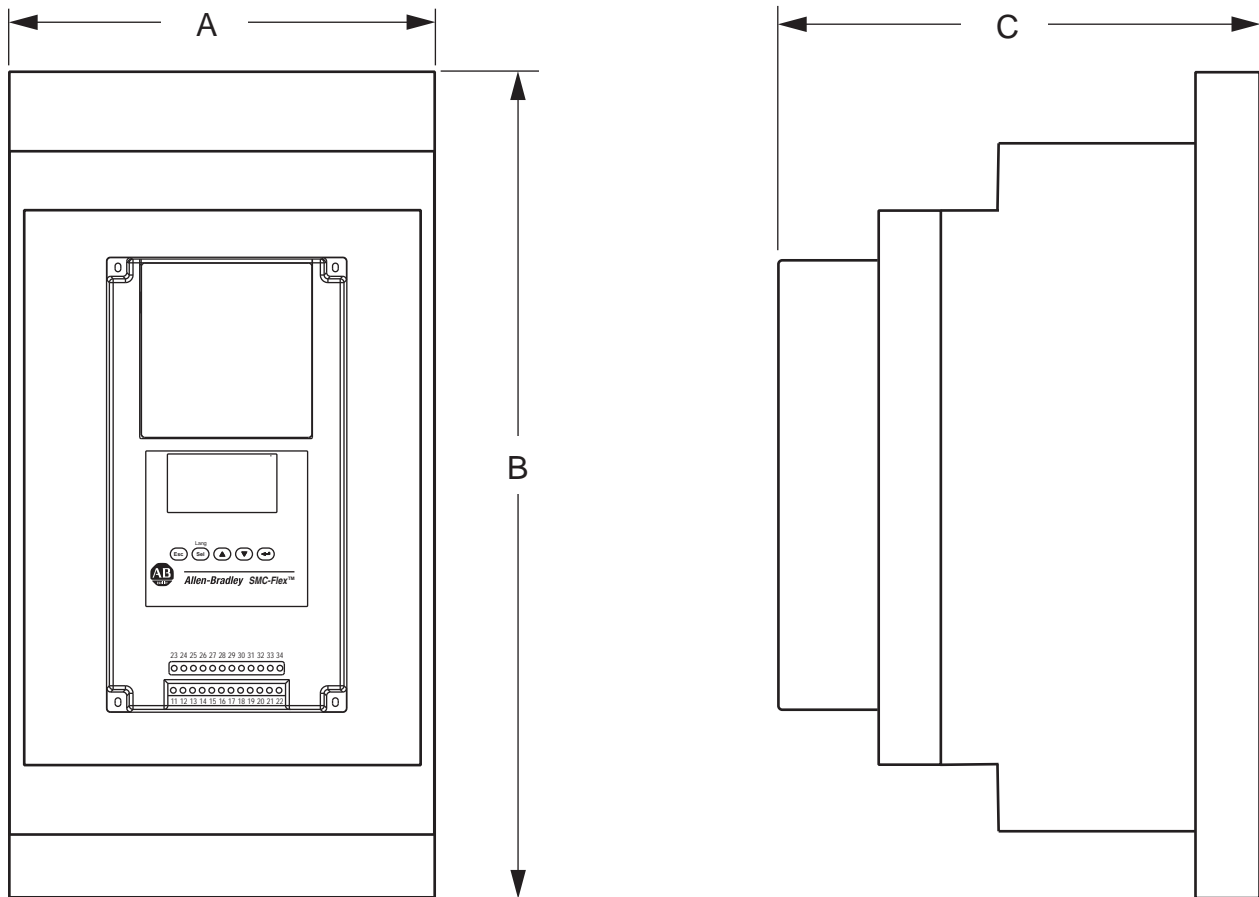

Dimensions are in millimeters (inches).

Controller Rating [A]	Height (B)	Width (A)	Depth (C)	Approximate Shipping Weight
5...85	321.0 (12.60)	150.0 (5.90)	203.0 (8.00)	5.7 kg (12.5 lb)
108...135	443.7 (17.47)	196.4 (7.74)	212.2 (8.35)	15.0 kg (33.0 lb)
201...251	560.0 (22.05)	225.0 (8.86)	253.8 (9.99)	30.4 kg (67.0 lb)
317...480	600.0 (23.62)	290.0 (11.42)	276.5 (10.89)	45.8 kg (101 lb)
625...780	1041.1 (41.00)	596.9 (23.50)	346.2 (13.63)	179 kg (395 lb)
970...1250	1041.1 (41.00)	596.9 (23.50)	346.2 (13.63)	224 kg (495 lb)

Power Wiring

Refer to the product nameplate or the SMC Flex User Manual for device specific information.

SMC Rating [A]	Lug Kit Cat. No.	Wire Strip Length	Conductor Range	Max. No. Lugs/Pole		Tightening Torque	
				Line Side	Load Side	Wire - Lug	Lug - Busbar
5...85	—	18...20 mm	2.5...85 mm ² (#14...3/0 AWG)	—	—	11.3 N•m (100 lb•in)	—
108...135	199-LF1	18...20 mm	16...120 mm ² (#6...250 MCM)	1	1	31 N•m (275 lb•in)	23 N•m (200 lb•in)
201...251	199-LF1	18...20 mm	16...120 mm ² (#6...250 MCM)	2	2	31 N•m (275 lb•in)	23 N•m (200 lb•in)
317...480	199-LG1	18...25 mm	25...240 mm ² (#4...500 MCM)	2	2	42 N•m (375 lb•in)	28 N•m (250 lb•in)
625...780	100-DL630	32 mm/64 mm	70...240 mm ² (2/0...500 MCM)	2	2	45 N•m (400 lb•in)	68 N•m (600 lb•in)
970	100-DL860	26 mm/48 mm	120...240 mm ² (4/0...500 MCM)	1	1	45 N•m (400 lb•in)	68 N•m (600 lb•in)
1250	100-DL630	32 mm/64 mm	70...240 mm ² (2/0...500 MCM)	1	1	45 N•m (400 lb•in)	68 N•m (600 lb•in)
	100-DL860	26 mm/48 mm	120...240 mm ² (4/0...500 MCM)	1	1		

Control Terminals

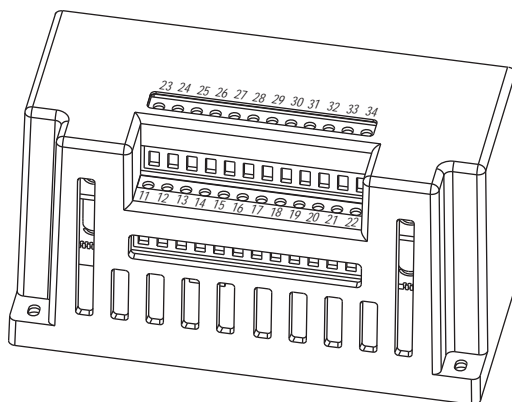

Terminal	Description	Terminal	Description	Footnotes
11 ^{③④}	Control Power Input (+)	23 ^①	PTC Input	<p>① Do not connect any additional loads to these terminals. These "parasitic" loads may cause incorrect operation.</p> <p>② When set for External Bypass mode, the SMC Flex can be used to control a properly sized external contactor and overload once the motor reaches full speed. The SMC-Flex overload functionality is disabled in this mode.</p> <p>③ RC Snubbers are required on inductive type loads connected to auxiliary contacts.</p> <p>④ Control power on units rated 625...1250 A is pre-wired internally, from terminal block CP1.</p>
12 ^{③④}	Control Power Common	24 ^①	PTC Input	
13 ^①	Controller Enable Input	25	Tachometer Input	
14	Ground	26	Tachometer Input	
15 ^{①③}	Option Input #2	27 ^①	Ground Fault Transformer Input	
16 ^{①③}	Option Input #1	28 ^①	Ground Fault Transformer Input	
17 ^{①③}	Start Input	29 ^{②③}	Aux Contact #2	
18 ^{①③}	Stop Input	30 ^{②③}	Aux Contact #2	
19 ^{②③}	Aux Contact #1	31 ^{②③}	Aux Contact #3	
20 ^{②③}	Aux Contact #1	32 ^{②③}	Aux Contact #3	
21	Not Used	33 ^{②③}	Aux Contact #4	
22	Not Used	34 ^{②③}	Aux Contact #4	

Control Wiring

Refer to the product nameplate for additional details. Depending on the specific application, additional control circuit transformer VA capacity may be required.

Controllers rated 5...480 A

Control power is connected to the product through terminals 11 and 12.

Conductor Range	0.75...2.5 mm ² (18...14 AWG)
Torque	0.6 N•m (5 lb•in)
Maximum Number of Wires per Terminal	2
AC Control Voltage Input	100...240V AC or 24V AC (+10/-15%)
Supply Type	1-phase, 50/60 Hz
24V AC Power Requirement	130VA
100...240V AC Power Requirement	75VA
DC Control Voltage Input	24V DC (+10/-15%)
Inrush Current	5 A
Inrush Time	250 ms
Transient Watts	60 W
Transient Time	500 ms
Steady State Watts	24 W
Recommended Supply	1606-XLP50E
Fan Power Input (AC only)	separately wired
F5...F135	20VA
F201...F251	40VA
F317...F480	60VA

Controllers rated 625...1250 A

Control power is connected to the product through terminal block CP1, at terminals 1 and 4.

Conductor Range	0.75...2.5 mm ² (18...14 AWG)
Torque	0.6 N•m (5 lb•in)
Maximum Number of Wires per Terminal	2
Control Voltage Input	110/120V AC or 230/240V AC, (+10/-15%)
Supply Type	1-phase, 50/60 Hz
Control Power Input	800VA (includes controller, bypass, and fans)

Typical Wiring Diagrams

Typical Power Wiring Examples

Diagrams per NEMA Symbolology

Line Connection with Isolation Contactor (Default Mode)

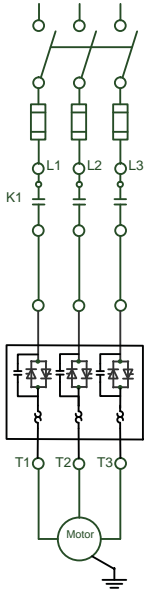

Delta Connection with Isolation Contactor (Optional Mode)

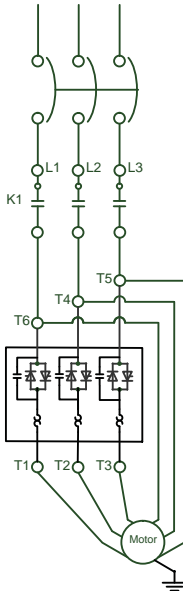

Delta Connection with Shorted SCR Protection (Optional Mode)

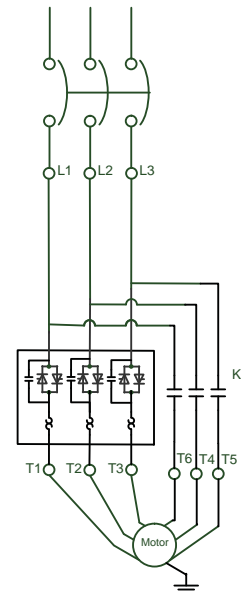

Diagrams per IEC Symbolology

Line Connection with Isolation Contactor (Default Mode)

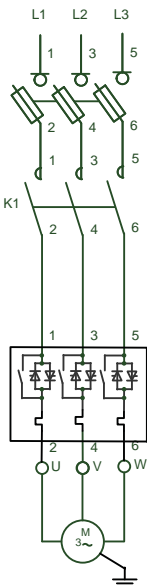

Delta Connection with Isolation Contactor (Optional Mode)

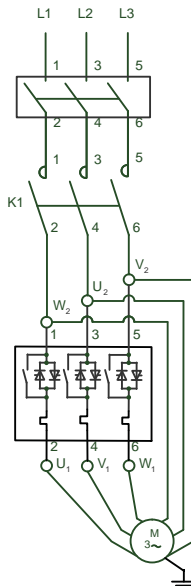

Delta Connection with Shorted SCR Protection (Optional Mode)

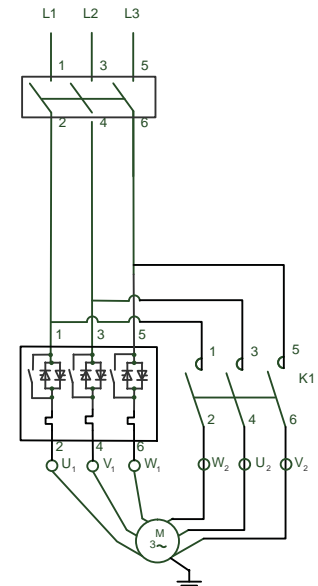

Typical Control Wiring Examples

Fig 1.x
2 Wire Control (No DPI control or Option Stopping) with Fault Indication

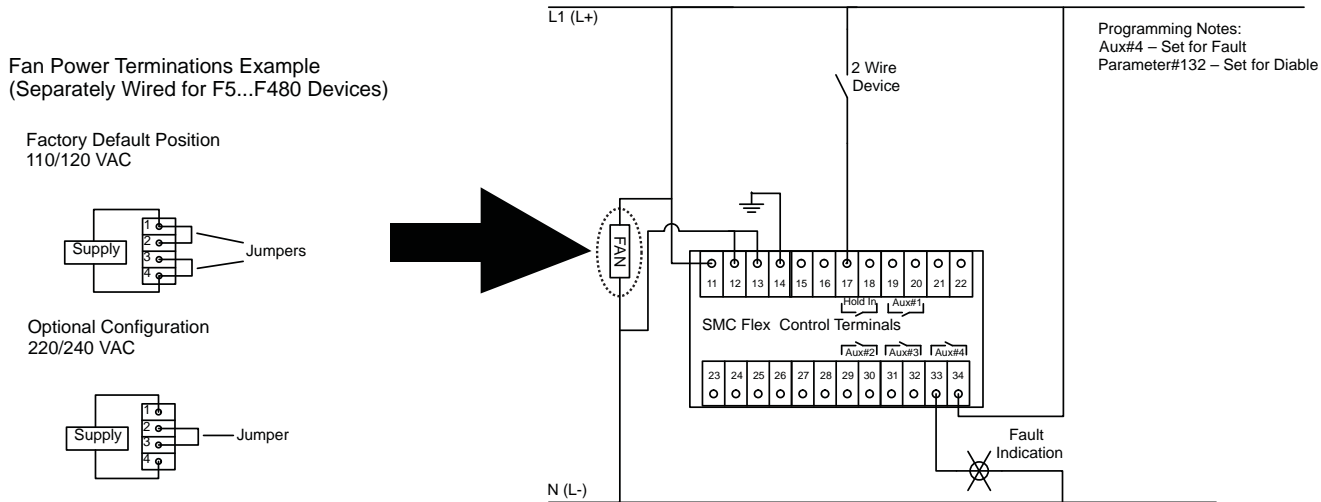
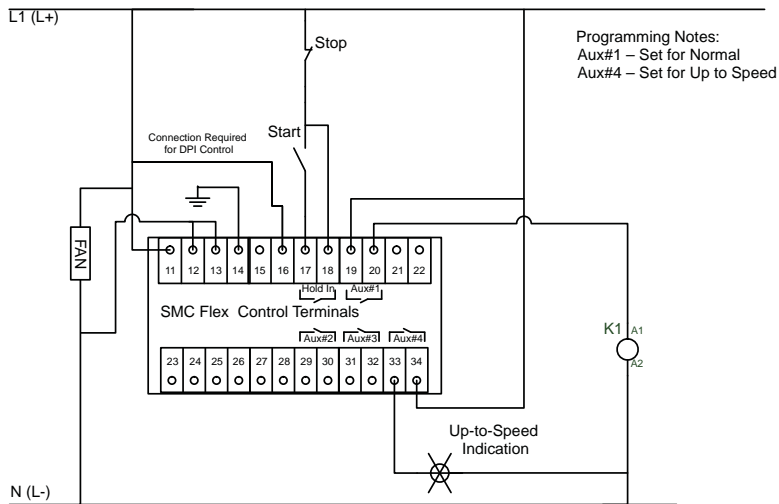

Fig 1.x
3 Wire Control (With or Without DPI control), Isolation Contactor (K1),
and Up-to-Speed Indication



Typical Control Wiring Examples, Continued

Fig 1.x
3 Wire Control with Option Stopping, DPI control, Isolation Contactor (K1),
and Alarm Indication

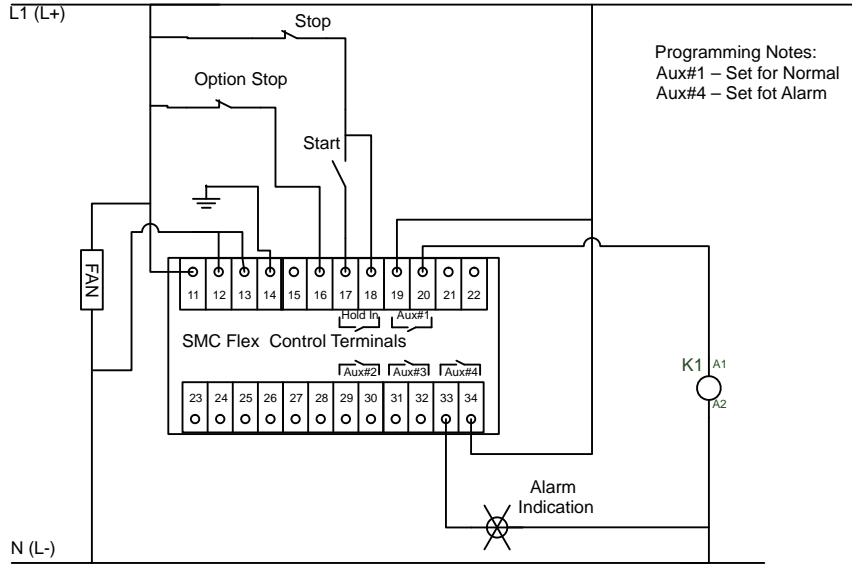
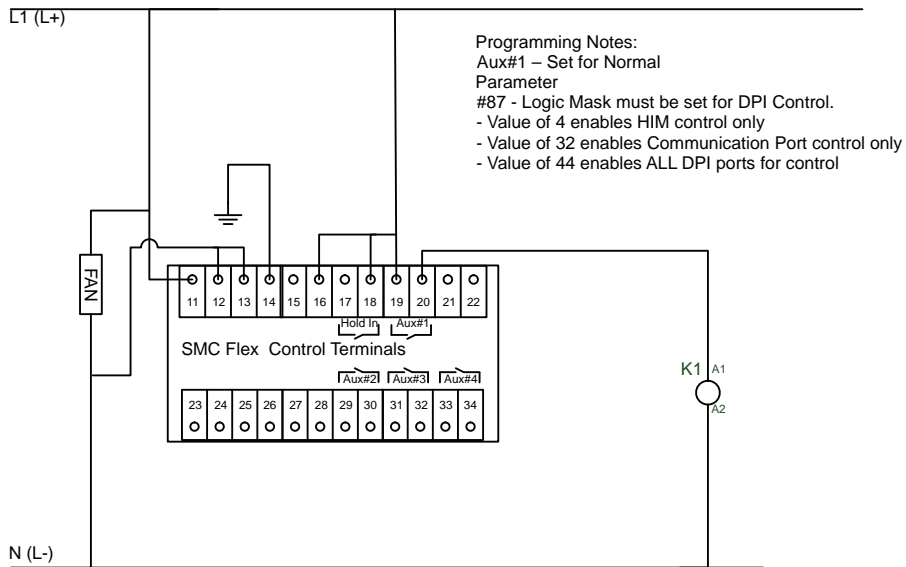

Fig 1.x
Start and Stop Control via DPI Communication ONLY with Isolation
Contactor (K1)



Step 3 - Basic Programming

The SMC-Flex controller can be programmed with the built-in keypad and LCD display or with an optional Bulletin 20-HIM-xx LCD human interface module.

Menu Structure Hierarchy

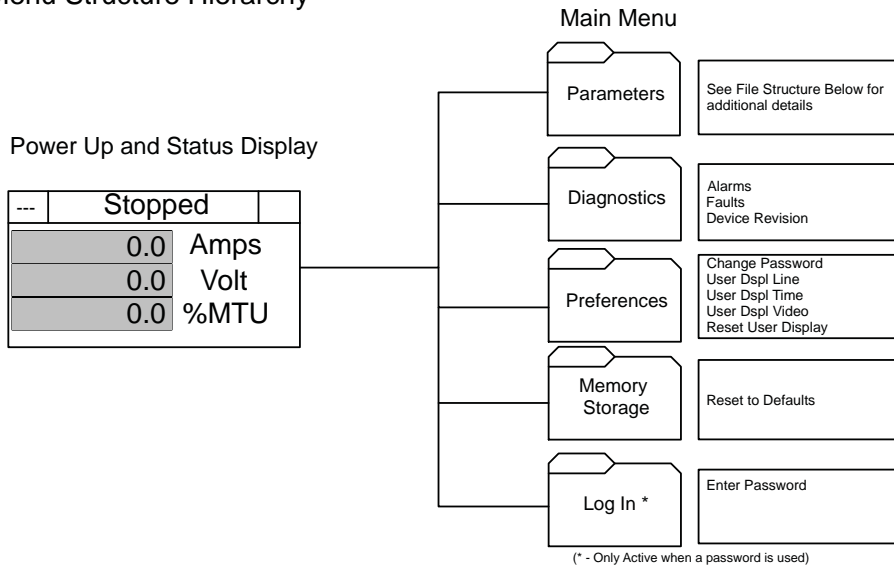

Monitoring	Set Up	Motor Protection		Communications	Utility	Linear List
Metering	Basic	Overload	Jam	Comm Masks	Language	Linear List
Volts Phase A-B Volts Phase B-C Volts Phase C-A Current Phase A Current Phase B Current Phase C Watt Meter Kilowatt Hours Elapsed Time Meter Reset Power Factor Mtr Thermal Usage	SMC Option Motor Connection Line Voltage Starting Mode Ramp Time Initial Torque Cur Limit Lvl Kickstart Time Kickstart Level Stop Input Option 1 Input Option 2 Input Stop Mode Stop Time Overload Class Service Factor Motor FLC Overload Reset Aux1 Config Aux2 Config Aux3 Config Aux4 Config Parameter Mgt	Overload Class Service Factor Motor FLC Overload Reset Overload A Lvl Parameter Mgmt	Jam F Lvl Jam F Dly Jam A Lvl Jam A Dly Parameter Mgmt	Logic Mask Parameter Mgmt	Language Parameter Mgmt	All Parameters
		Underload	Stall	Data Links	Motor Data	
		Underload F Lvl Underload F Dly Underload A Lvl Underload A Dly Parameter Mgmt	Stall Delay Parameter Mgmt	Data In A1 Data In A2 Data In B1 Data In B2 Data In C1 Data In C2 Data In D1 Data In D2 Data Out A1 Data Out A2 Data Out B1 Data Out B2 Data Out C1 Data Out C2 Data Out D1 Data Out D2 Parameter Mgmt	Motor FLC Motor ID Parameter Mgmt	
		Undervoltage	Ground Fault			
		Undervoltage F Lvl Undervoltage F Dly Undervoltage A Lvl Undervoltage A Dly Parameter Mgmt	Gnd Flt Enable Gnd Flt Lvl Gnd Flt Dly Gnd Flt Inh Time Gnd Flt A Enable Gnd Flt A Lvl Gnd Flt A Dly Parameter Mgmt			
		Overvoltage	PTC			
		Overvoltage F Lvl Overvoltage F Dly Overvoltage A Lvl Overvoltage A Dly Parameter Mgmt	PTC Enable Parameter Mgmt			
		Unbalance	Phase Reversal			
		Unbalance F Lvl Unbalance F Dly Unbalance A Lvl Unbalance A Dly Parameter Mgmt	Phase Reversal Parameter Mgmt			
			Restart			
			Starts Per Hour Restart Attempts Restart Delay Parameter Mgmt			

Note:
 • Depending on the SMC option, additional parameters may appear in some menus
 • The external HIM has similar programming operation to the built-in HIM, however some differences do exist.
 • The built-in HIM can not be used to program other DPI devices (i.e. Device Select)

Access the *Basic* set up group by selecting the *Parameters* menu from the Main Menu and then *Set Up*. This programming group provides a limited parameter set, allowing quick start-up with minimal adjustment.

Parameter Name and Description	Values	Default
Parameter # 14 - SMC Option Displays the type of controller. This is factory set and not adjustable.	Standard, Pump Control, Brake	Read Only
Parameter # 15 - Motor Connection Displays the motor type to which the device is being connected.	Line or Delta	Line
Parameter # 16 - Line Voltage Displays the system line voltage to which the unit is connected.	0...10000	480
Parameter # 17 - Starting Mode Allows the user to program the SMC-Flex controller for the type of starting that best fits the application.	Soft Start, Current Limit, Full Voltage, Linear Speed, Pump Control	Soft Start
Parameter # 18 - Ramp Time This sets the time period during which the controller will ramp the output voltage.	0...30 s	10
Parameter # 19 - Initial Torque When the Soft Start mode is selected, this parameter sets the initial reduced voltage output level for the voltage ramp.	0...90% of locked rotor torque	70
Parameter # 20 - Current Limit Level When Current Limit mode is selected, this parameters sets level of current that is applied for the programmed Ramp Time.	50...600% FLC	350
Parameter # 22 - Kickstart Time A boost current is provided to the motor for the programmed time period.	0.0...2.0 s	0
Parameter # 23 - Kickstart Level Adjusts the amount of current applied to the motor during kickstart.	0...90% of locked rotor torque	0
Parameter # 133 - Stop Input Allows the user to select the operation of terminal 18, Stop Input.	Coast, Stop Option	Coast
Parameter # 132 - Option Input 1 Allows the user to select the operation of terminal 16, Option Input #1.	Disable, Coast, Stop Option, Fault, Fault NC, Network	Stop Option
Parameter # 24 - Option Input 2 Allows the user to select the operation of terminal 15, Option Input #2.	Disable, Slow Speed, Dual Ramp, Fault, Fault NC, Network, Clear Fault	Disable
Parameter # 32 - Stop Mode Allows the user to program the SMC Flex controller for the type of stopping that best fits the application.	Soft Stop, Linear Speed, SMB, Accu-Stop, Pump Stop	Soft Stop
Parameter # 33 - Stop Time This sets the time period which the controller will ramp the voltage during a stopping maneuver.	0.0...120 s	0.0
Parameter # 44 - Overload Class Allows the user to enter the desired Overload trip class for the motor.	Disable, 10, 15, 20, 30	10
Parameter # 45 - Service Factor Allows the user to enter the Service Factor of the motor. For IEC motors the typical value is 1.0. For NEMA	0.01...1.99	1.15
Parameter # 46 - Motor FLC This is a user entered value that is needed so the device can provide proper motor Overload protection.	1.0...2200	1.0
Parameter # 47 - OL Reset Mode This value allows the user to define how the overload can reset.	Auto, Manual	Manual
Parameter # 107 - Aux1 Config Auxiliary 1 contact is located at terminals 19 and 20 and allows the user to configure the operation of the contact.	Normal, Up-to-speed, Fault, Alarm, Network Control, External Bypass: (N.O./N.C.)	Normal
Parameter # 110 - Aux2 Config Auxiliary 2 contact is located at terminals 29 and 30 and allows the user to configure the operation of the contact.	Normal, Up-to-speed, Fault, Alarm, Network Control, External Bypass: (N.O./N.C.)	Fault
Parameter # 108 - Aux3 Config Auxiliary 3 contact is located at terminals 31 and 32 and allows the user to configure the operation of the contact.	Normal, Up-to-speed, Fault, Alarm, Network Control, External Bypass: (N.O./N.C.)	Alarm
Parameter # 109 - Aux4 Config Auxiliary 4 contact is located at terminals 33 and 34 and allows the user to configure the operation of the contact.	Normal, Up-to-speed, Fault, Alarm, Network Control, External Bypass: (N.O./N.C.)	Normal
Parameter # 115 - Parameter Mgmt Allows the user the ability to recall all Factory default parameter values.	Ready, Load Default	Ready

Step 4 - Operation and Troubleshooting

Start Up Check List

1. Verify Input Supply voltage and wiring
2. Check output wiring
3. Check control wiring
4. Apply control power
5. Test local start/stop control

Monitoring

The SMC Flex controller has built in diagnostics and metering functions which can be accessed through a local or remote LCD display.

Step	Action
1	From any menu, Press Esc to get to the MAIN Device display.
2	If using the built in display, Press Enter and continue to step #3. If using a remote HIM, first make sure that the SMC Flex is displayed by going to MAIN MENU / DEVICE SELECT / SMC FLEX Press Enter and continue to step #3.
3	To View or Review the Metering Information - Access the metering parameters by selecting PARAMETER / MONITORING / and then METERING. Press enter to view any selected value.

Viewing and Clearing Faults

Step	Action
1	Press Esc to acknowledge the fault. The fault information will be removed so that you can use the HIM.
2	To View or Review the fault information - Go to MAIN MENU / DIAGNOSTICS / FAULTS / VIEW FAULT QUEUE. - Or look at parameters 124...128.
3	Address the condition that caused the fault. The cause must be corrected before the fault can be cleared.
4	After corrective action has been taken, clear the fault by one of these methods: - Press and Hold the ESC key for 3 seconds. - Cycle control power to the device. - Press Stop key on an External HIM. - Program the SMC-Flex controller for a CLEAR FAULT, which can be found in MAIN MENU / DIAGNOSTICS / FAULTS. - Option Input #2 (terminal 15) can be configured to clear faults with the use of N.O. push button.

Troubleshooting - Abbreviated Listing

For a complete list of fault codes and troubleshooting tips, refer to the SMC Flex User Manual.

Display Fault	Fault Code	Enabled	Possible Causes	Possible Solutions
Line Fault with Phase Indication	1, 2, 3	prestart only	Missing supply phase Motor not connected properly Incoming 3-phase voltage instability	Check for open line (i.e., blown fuse) Check for open load lead Verify power quality
Shorted SCR with Phase indication	4, 5, 6	all	Shorted power module	Check for shorted SCR, replace power module if necessary
Open Gate with Phase Indication	7, 8, 9	start or stop	Open gate circuitry Loose gate lead	Perform resistance check; replace power module if necessary Check gate lead connections to the control module
PTC Power Pole and SCR Overtemp	10, 11		Controller ventilation blocked Controller duty cycle exceeded Fan failure Ambient temperature limit exceeded Failed thermistor	Check for proper ventilation Check application duty cycle Wait for motor to cool or provide external cooling Replace power module or control module as needed Replace fan
Motor PTC	12	running	Motor ventilation blocked Motor duty cycle exceeded PTC open or shorted	Check for proper ventilation Check application duty cycle Wait for motor to cool or provide external cooling Check resistance of PTC
Open Bypass with phase indication	13, 14, 15	running	Control voltage is low Inoperable power module bypass	Check control voltage power supply Replace power module Check control module TB2...TB4 and TB5...TB7 for secureness Check Aux 1, 2, 3, 4 configurations are not set to External Bypass
No Load Fault	16, 17, 18, 40	prestart only	Loss of load side power wiring Start command cycled unexpectedly with motor rotating	Check all load side power connections Check motor windings
Line Unbalance	19	running	Supply unbalance is greater than the user-programmed value The delay time is too short for the application	Check power system and correct if necessary Extend the delay time to match the application requirements
Overvoltage	20	running	Supply voltage is greater than user programmed value The delay time is too short for the application	Check power system and correct if necessary Correct the user-programmed value Extend the delay time to match the application requirements
Undervoltage	21	running	Supply voltage is less than user programmed value The delay time is too short for the application	Check power system and correct if necessary Correct the user-programmed value Extend the delay time to match the application requirements
Overload	22	running	Motor overloaded Overload parameters are not matched to the motor	Check motor overload condition Check values for overload class and motor FLC Verify current draw of the motor
Underload	23	running	Broken motor shaft, belts, toolbits, etc.. Pump cavitation Incorrect user setting	Check pump system, machine drive components, and loading Check settings Repair or replace motor
Jam	24	running	Motor current has exceeded the user programmed jam level	Correct source of jam or excessive loading Check programmed time value
Stall	25	running	Motor did not reach full speed by the end of the programmed ramp time Incorrect user setting	Correct source of stall or excessive loading Adjust SMC starting parameters to compensate for load
Phase Reversal	26	prestart only	Incoming supply voltage is not in the expected ABC sequence	Check power wiring, correct if necessary
Network and Comm's Loss	30, 31, 32 27, 28, 29	all	DPI network loss Communication disconnection at the serial port	Check communication adapters and verify connection to SMC Reconnect each DPI connected device
Ground Fault	33	running	Ground fault current level has exceeded programmed value The delay time is too short for the application	Check power system and motor; correct if necessary Check programmed ground fault levels to match application requirements Extend the delay time to match the application requirements
Power Loss with phase indication	35, 36, 37	start or stop	Missing supply phase (as indicated) Internal CT problem	Check for open line (i.e., blown line fuse) Replace power pole as indicated
Line Loss with phase indication	41, 42, 43	start or stop	Incoming 3-phase voltage instability or distortion High impedance connection	Check supply voltage for capability to start/stop motor Check for loose connections on line side or motor side of power wires Verify and correct input power quality
Internal 24V and System Faults	44, 45, 46, 128...209	all	Low line condition Excessive load on	Check the control power, verify it is within the specification Check connections and grounding to the SMC control terminals Replace control module

Repair Parts

Description		SMC Rating	Part No. ①			
			For units rated 200...600V AC		For units rated 690V AC	
			100...240V AC	24V AC/DC	100...240V AC	
Control Modules	Standard	All	41391-454-01-S1FX	41391-454-02-S2FX	41391-454-05-S1FZ	
	Pump	All	41391-454-01-B1FX	41391-454-02-B2FX	41391-454-05-B1FZ	
	Braking	5...85 A	41391-454-01-D1AX	41391-454-02-D2AX	41391-454-05-D1AZ	
		108...251 A	41391-454-01-D1BX	41391-454-02-D2BX	41391-454-05-D1BZ	
		317...480 A	41391-454-01-D1CX	41391-454-02-D2CX	41391-454-05-D1CZ	
		625...780 A	41391-454-01-D1DX	N/A	41391-454-05-D1DZ	
	970...1250 A	41391-454-01-D1EX	N/A	41391-454-05-D1EZ		
Description		SMC Rating	Series	Part No. ①		
				Line Voltage		
				200...480V	200...600V	230...690V
Power Poles	5 A	B	150-FPP5B ②	150-FPP5C ②	N/A	
	25 A	B	150-FPP25B ②	150-FPP25C ②	N/A	
	43 A	B	150-FPP43B ②	150-FPP43C ②	N/A	
	60 A	B	150-FPP60B ②	150-FPP60C ②	N/A	
	85 A	B	150-FPP85B ②	150-FPP85C ②	N/A	
	108 A	A	41391-800-01 ③	41391-800-02 ③	N/A	
	135 A	A	41391-800-03 ③	41391-800-04 ③	N/A	
	108 A	B	150-FPP108B ②	150-FPP108C ②	150-FPP108Z ②	
	135 A	B	150-FPP135B ②	150-FPP135C ②	150-FPP135Z ②	
	201 A	B	150-FPP201B	150-FPP201C	150-FPP201Z ③	
	251 A	B	150-FPP251B	150-FPP251C	150-FPP251Z ③	
	317 A	B	150-FPP317B	150-FPP317C	150-FPP317Z ③	
	361 A	B	150-FPP361B	150-FPP361C	150-FPP361Z ③	
	480 A	B	150-FPP480B	150-FPP480C	150-FPP480Z ③	
	625 A	B	150-FPP625B	150-FPP625C	150-FPP625Z ③	
	780 A	B	150-FPP780B	150-FPP780C	150-FPP780Z ③	
	970 A	B	150-FPP970B	150-FPP970C	150-FPP970Z ③	
1250 A	B	150-FPP1250B	150-FPP1250C	150-FPP1250Z ③		
Heatsink Fans		5...85 A	B	41391-801-03		
		108...135 A	B	41391-801-03		
		201...251 A	B	41391-801-01		
		317...480 A	B	41391-801-02		
	110/120V AC Control Power	625...1250 A	B	41391-801-04		
	230/240V AC Control Power	625...1250 A	B	41391-801-05		
Base Plate		201...251 A	B	41391-803-01		
		317...480 A	B	41391-803-02		
By-Pass Contactor ④	110/120V AC Control Power	625...780 A	B	100-D180ED11		
		970...1250 A	B	100-D420ED11		
	230/240V AC Control Power	625...780 A	B	100-D180EA11		
		970...1250 A	B	100-D420EA11		

- ① One piece provided per part number.
- ② Three-phase power pole structure provided per part no.
- ③ One-phase power pole provided per part no.
- ④ Refer to Appendix D in the SMC Flex User Manual, for installation instructions.

www.rockwellautomation.com

Power, Control and Information Solutions Headquarters

Americas: Rockwell Automation, 1201 South Second Street, Milwaukee, WI 53204-2496 USA, Tel: (1) 414.382.2000, Fax: (1) 414.382.4444

Europe/Middle East/Africa: Rockwell Automation, Vorstlaan/Boulevard du Souverain 36, 1170 Brussels, Belgium, Tel: (32) 2 663 0600, Fax: (32) 2 663 0640

Asia Pacific: Rockwell Automation, Level 14, Core F, Cyberport 3, 100 Cyberport Road, Hong Kong, Tel: (852) 2887 4788, Fax: (852) 2508 1846